

[CONTRIBUTION FROM THE GEORGE HERBERT JONES LABORATORY, THE UNIVERSITY OF CHICAGO]

## THE PHOTOCHEMICAL POLYMERIZATION OF CYANOGEN

BY T. R. HOGNESS AND LIU-SHENG TS'AI

RECEIVED AUGUST 8, 1931

PUBLISHED JANUARY 7, 1932

Cyanogen, when heated, forms a solid polymerization product known as paracyanogen, having the empirical formula  $(CN)_x$ . Its structural formula is unknown, but by analogy with the polymerization products of cyanogen halides<sup>1</sup> it has been assumed that three molecules of cyanogen form one molecule of paracyanogen. Polymerization has been effected not only by heating<sup>2</sup> but by photochemical means and by bombardment with  $\alpha$ -particles<sup>3</sup> as well. Berthelot and Gaudechon<sup>4</sup> carried out the photochemical polymerization in a very qualitative way, and their results gave only the information that the reaction was a photochemical one and that it could be effected by light of convenient frequency. In beginning the more detailed study of this reaction, we found that we were quite unable to reproduce their work, and that the problem was somewhat more difficult of attainment than their results seemed to indicate.

### Absorption Measurements

Before beginning the photochemical investigation, it was necessary to obtain information regarding the absorption spectrum of cyanogen. To this end we first employed a Hilger E-2 quartz spectrograph, a hydrogen discharge tube, and a quartz absorption cell 20 cm. long filled with cyanogen at one atmosphere. With the dispersion afforded by this spectrograph we obtained a set of diffuse bands to the short wave length side of about 2230 Å. To determine whether these bands were really diffuse or whether they appeared so through lack of dispersion of our instrument, we made new photographs employing the larger Hilger E-1. This instrument gives a dispersion of approximately 1.5 Å. per mm. in the neighborhood of 2200Å. Even with this dispersion, which should certainly resolve any bands due to as light a molecule as cyanogen, the bands still appeared diffuse. Using the lines of the copper arc as standards of comparison, the wave lengths of the bands were measured. Table I gives the limits of each of these bands.

The lowest wave length observed corresponds to the limit of transmission of the quartz. It will be observed that there is no regularity in either the width of each band or in their relative positions.

The fact that the absorption bands are diffuse has led us to the conclusion

<sup>1</sup> Mulder, *Rec. trav. chim.*, **5**, 84 (1886); **6**, 199 (1887).

<sup>2</sup> Troost and Hautefeuille, *Compt. rend.*, **66**, 795 (1868).

<sup>3</sup> Lind, Bardwell and Perry, *THIS JOURNAL*, **48**, 1556, 1575 (1926).

<sup>4</sup> Berthelot and Gaudechon, *Compt. rend.*, **150**, 1169 (1910).

TABLE I

WAVE LENGTH LIMITS OF THE ABSORPTION BANDS OF CYANOGEN IN ÅNGSTRÖM UNITS

2240-2241	2203-2202	2171-2168
2230-2227	2196-2190	2162-2157
2219-2216	2186-2176	2152-2149
2207-2206.5	2175-2173	2146-2145
2205-2204		

that the primary step in the process is one of predissociation; that the  $C_2N_2$  molecule upon light absorption dissociates. Cyanogen may dissociate on light absorption either into two cyanogen radicals (one may be in the excited state) or into  $N_2$  and  $C_2$ . From our usual conception of the structure of the cyanogen molecule, one would presuppose that the former products rather than  $N_2$  and  $C_2$  would be formed. This is substantiated by the fact that in our later photochemical experiments no evidence of free carbon was found and by the fact that Berthelot and Gaudechon<sup>4</sup> found neither nitrogen nor carbon as a polymerization product. Furthermore, on passing a weak discharge through cyanogen, only the CN bands were observed.

All the evidence points to the dissociation of cyanogen into CN radicals. The following simple thermochemical calculation will show that such a dissociation is possible

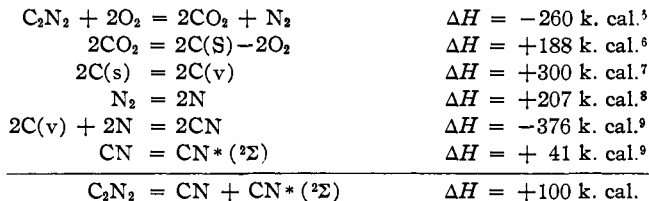

The energy corresponding to the band of the longest wave length observed is 127 k. cal., sufficient to give the products indicated above. A similar calculation shows that this limiting wave length is sufficient to dissociate the cyanogen molecule into normal  $N_2$  and  $C_2$ , but not if one of these products is to be in any one of the known excited electronic states.

Our calculation has shown that the absorbed energy is sufficient to dissociate the  $C_2N_2$  molecule into a normal CN radical and a CN radical either in the  $^2\Sigma$  state (3.19 volts) or in the  $^2\pi$  state (1.78 volts). The CN radicals in either of these states should give rise to fluorescent radiation if the pressure were such that little damping of that fluorescence took place. Inasmuch as cyanogen absorbs light only very weakly at low pressure, it

<sup>5</sup> "International Critical Tables," Vol. V, p. 167.

<sup>6</sup> *Ibid.*, Vol. V, p. 181.

<sup>7</sup> Kohn and Guckel, *Naturwiss.*, **12**, 139 (1924).

<sup>8</sup> Mullikan and Birge, *Nature*, **122**, 844 (1928).

<sup>9</sup> Villars, *THIS JOURNAL*, **52**, 61 (1930).

would hardly be expected that such a fluorescence could be detected and, in fact, all efforts to obtain any trace of fluorescence were in vain. We employed as a light source a zinc spark, a cadmium spark and a hydrogen discharge tube and in all cases the pressure of the absorbing gas was in the neighborhood of 1 mm. This pressure we guessed to be about an optimum one in view of the small absorption of this gas, and the maximum damping pressure of others. Using the Steinheil spectrograph ( $f = 2.8$ ), with several exposures of six to twelve hours each we obtained no trace of a fluorescence spectrum.

The fact that no fluorescence was obtained does not argue against the assumption that one of the CN radicals is left in an excited state. Were the absorption as great as that of iodine, one might use such an argument, but in this case the absorption is considerably less.

The wave length of the effective light was such that in our photochemical experiments we were unable to use a monochromator but the range was so narrow (2240–2145 Å.) that this was unnecessary. We could without any appreciable error assume a mean effective wave length of 2150 Å. We did not therefore determine wave lengths but rather determined the total absorption in the same cell that was used in the photochemical experiments.

The variations in intensity of the light source used in the absorption measurements (described later) and the unsteadiness of the thermopile circuit were large enough so that we could not with assurance use the usual method of measuring the light intensity with a full and empty cell alternated in the light path. We found that the following method gave reproducible results.

The absorption cell was a cylindrical tube 25 mm. long and 2 cm. in diameter with quartz windows at each end. This tube was connected with an intervening stopcock to a liter bulb which in turn was connected to a mercury reservoir. Acting similarly to a Töpler pump, the gas in the one-liter bulb could be compressed into the absorption cell and the stopcock closed. The one-liter bulb could be evacuated by lowering the mercury reservoir and then upon opening the stopcock the gas could be expanded to about 125 times its initial volume and the pressure reduced correspondingly.

The procedure then was to have the light from the hydrogen discharge tube pass through the absorption cell full of gas and onto the thermopile. When the galvanometer in the thermopile circuit was exceptionally steady, the stopcock was opened, the gas in the cell expanded, and the deflection of the galvanometer noted. In all the absorption measurements the gas was at a pressure of one atmosphere in the absorption cell. When the stopcock was opened, the gas remaining was at a pressure of about 6 mm., and this latter pressure we considered to be ineffective in our calculations.

The result of ten individual experiments gave an absorption of 8.8 ( $\pm 0.6$ ) % of the total radiation passing through the cell.

### Determination of Quantum Efficiency

Preliminary experiments with the quartz mercury vapor lamp, the cadmium spark, the zinc spark and the hydrogen discharge tube as light sources showed that only the latter could be used effectively in this experiment.

Berthelot and Gaudechon obtained an 18.5% contraction in volume when cyanogen was subjected to the radiation of a quartz mercury vapor lamp. Repeating this work and loading our lamp to its full capacity, we were unable to obtain any appreciable volume contraction in this time. A consideration of the emission spectrum of the mercury lamp and the absorption spectrum of cyanogen makes it improbable that such an effect should be observed when pure cyanogen was used, since there are no emission lines in the region of absorption. The same is true for the cadmium spark. The spectrum of the zinc spark shows strong lines below the limit of absorption, but these were apparently not of sufficient intensity after passing through the quartz window, or they occurred in a region of no absorption. Lacking details we cannot venture any explanation of Berthelot and Gaudechon's positive results other than that their cyanogen contained some sensitizing agent.

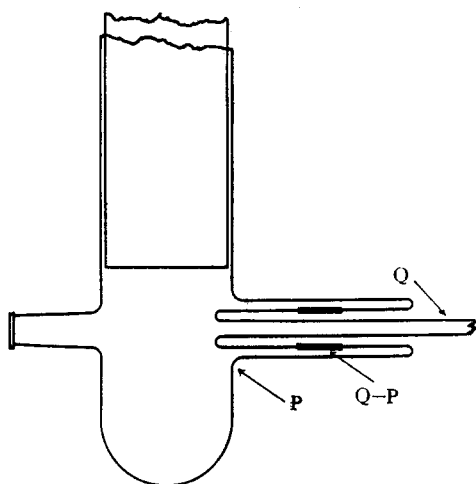

Fig. 1.—P, Pyrex; Q, quartz; Q—P quartz—Pyrex seal.

The hydrogen discharge tube was a modification of the one described by Lawrence and Edlefsen.<sup>10</sup> Instead of using sealing wax to join the quartz tube to the Pyrex electrode cylinders, we used a quartz—Pyrex seal as shown in Fig. 1.

The current was supplied through a 6600 volt 25 k. v. a. transformer equipped with a resistance in the primary circuit. The usual operating voltage and current through the tube were 3000 volts and 5 to 6 amperes, respectively. With this load the tube usually broke down at the end of about two weeks of running.

The cyanogen used in all these experiments was prepared by heating recrystallized silver cyanide in a previously evacuated line. Before being used the gas was dried over phosphorus pentoxide and purified by three fractionations.

The decrease in the amount of cyanogen in any single run was so small

<sup>10</sup> Lawrence and Edlefsen, *Rev. Sci. Instr.*, 1, 45 (1930).

that we were unable to employ the usual manometric method with mercury as the manometer medium. We had to resort, therefore, to the use of some organic liquid as the manometer medium, employ a tilted mercury manometer, or use a horizontal tube containing a bead of mercury. The last two methods have the disadvantage that the mercury tends to stick to the sides of the tube but since cyanogen is slightly soluble in organic liquids and since the rate of pressure decrease was so small, we adopted the last-named method, *i. e.*, the horizontal tube holding a bead of mercury. When precautions were taken to have the capillary tube very clean and the mercury very pure, and with continual tapping of the tube, consistent results were obtained. The apparatus used to determine the rate of volume decrease was nothing more than the cell used in the absorption measurements connected to the capillary as a side tube. This tube was placed in the path of the light beam near the discharge tube and the thermopile immediately behind it. The cell was shielded and its temperature at all times known by means of Beckmann thermometers.

As the reaction proceeded, the polymer formed as a faint cloud and settled to the bottom of the tube. Unfortunately some of the polymer gathered on the end windows and only the first part of each run could be used for our calculation. Knowing the rate of volume decrease and the light intensity, and after integrating the intensity over the cross section of the light beam and calibrating the thermopile against a standard lamp, we were able to calculate the quantum efficiency. Table II gives the results of six runs.

TABLE II  
QUANTUM EFFICIENCY OF POLYMERIZATION OF CYANOGEN

Run	Length of run, min.	No. of molecules of (CN) <sub>2</sub> polymerized	No. of quanta absorbed	Moles per einstein
1	21	$5.8 \times 10^{17}$	$2.22 \times 10^{17}$	2.6
2	25	$10.1 \times 10^{17}$	$3.28 \times 10^{17}$	3.1
3	18	$6.4 \times 10^{17}$	$2.74 \times 10^{17}$	2.4
4	22	$8.9 \times 10^{17}$	$3.02 \times 10^{17}$	3.0
5	24	$10.6 \times 10^{17}$	$2.68 \times 10^{17}$	3.0
6	25	$9.7 \times 10^{17}$	$2.9 \times 10^{17}$	3.3
				Av. 3.0 <sup>a</sup>

<sup>a</sup> One run gave a value of 4.6 moles per einstein for the quantum efficiency. Since this value deviated from the mean to a much larger extent than the others (over 50%) we have felt justified in omitting this from the table.

In the calculation we have used 2150 Å. as the mean wave length. This mean was selected by an examination of the photograph of the absorption spectrum.

The paracyanogen was distinctly brown in color. Upon heating it *in vacuo* the product volatilized, leaving no solid residue.

Since there was some mercury vapor present in our cell, the question might naturally arise as to the possibility of photochemical sensitization by the mercury. To test this we made a run with the mouth of a small flask of boiling mercury just under the path of the beam between the discharge tube and the absorption cell. There was no apparent difference between the polymerization rates with and without the intervening mercury vapor. The reaction in our case, therefore, was not due in any appreciable extent to a sensitized reaction.

### Discussion

The low quantum efficiency obtained for this reaction precludes any long chain reaction accounting for the mechanism of polymerization. As the first step of the mechanism we feel that the evidence given by the diffuse bands and the lack of free carbon points to a dissociation into CN radicals.

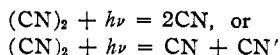

The simplest mechanism to account for a quantum efficiency of three moles per einstein would have as the second step

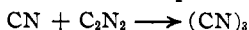

The last product could, if unstable, then form a larger group by secondary polymerization.

Although we have obtained only diffuse bands in the absorption spectrum, Henri<sup>11</sup> in a table in his "Structure des Molecules" gives a region of fine structured bands from 2385 to 2200 Å. With a tube 20 cm. long filled with cyanogen to one atmosphere pressure we did not detect the faintest trace of these bands. We can only surmise that Henri's cyanogen contained some foreign matter. The same, we suspect, applies to the work of Berthelot and Gaudechon, since cyanogen does not absorb any of the lines of the quartz mercury vapor lamp.

Lind, Bardwell and Perry<sup>3</sup> in their work on the polymerization of cyanogen by  $\alpha$ -particles found that about seven molecules polymerized per ion pair. The mechanisms in their case and that in ours are apparently different. There is no reason to suppose that these mechanisms should be the same in the two cases, particularly since no long chain reaction is involved. These authors described their product as a black polymer. The product in our case was distinctly brown. This difference, however, might easily be accounted for by the small side reaction liberating nitrogen, which these authors found.

### Summary

1. The absorption spectrum of cyanogen consists of a series of diffuse bands extending from 2240 Å. to the limit of transmissivity of quartz.

<sup>11</sup> V. Henri, "Structure des Molecules," J. Hermann et Cie, Paris, France, p. 99.

2. The conclusion is drawn that upon absorption of light between 2145 and 2240 Å., cyanogen dissociates (predissociation) into either two normal CN radicals or one normal and one excited.

3. No cyanogen fluorescence was obtained.

4. The quantitative absorption of light by cyanogen in the region 2145 to 2140 Å. was determined.

5. The quantum efficiency for the photochemical reaction  $(\text{CN})_2 \rightarrow$  paracyanogen was determined to be three moles per einstein.

6. A brief discussion of the mechanism, together with a discussion of the results of other investigators on the polymerization of cyanogen, concludes the work.

CHICAGO, ILLINOIS

---

[CONTRIBUTION FROM THE CHEMICAL LABORATORY OF NORTHWESTERN UNIVERSITY]

## THE DENSITY AND SURFACE TENSION OF LIQUID HYDROGEN FLUORIDE

By J. H. SIMONS AND J. W. BOUKNIGHT

RECEIVED AUGUST 8, 1931

PUBLISHED JANUARY 7, 1932

Hydrogen fluoride is a substance of considerable interest because of its unusual properties.<sup>1</sup> The vapor has been shown to consist of an equilibrium between HF and  $\text{H}_2\text{F}_2$ .<sup>2</sup> There are, however, very few available data about the anhydrous liquid upon which one may even make assumptions as to the molecular condition in the liquid state. This is of particular interest because the heat of vaporization as calculated from the vapor pressure curve<sup>3</sup> is constant over a wide temperature range. The heat of vaporization calculated in this manner is for one mole of the gas independent of the weight of the molecules. As the apparent molecular weight of the gas changes considerably with temperature and the heat of polymerization<sup>2</sup> is fairly high, one may be led to assume that the liquid has the same apparent molecular weight as the gas. Kolosovskii<sup>4</sup> has assumed this at the boiling point, because the liquid obeys Trouton's rule. This would seem to be a peculiar behavior. The material presented in this paper represents the beginning of an attack upon this problem.

The anhydrous liquid was prepared in the manner described by Simons<sup>3</sup> and was condensed directly into the apparatus in which it was to be used.

**The Density.**—The apparatus used to make the density determinations is shown in Fig. 1. This consisted of a cylindrical vessel of copper 2.5 cm.

<sup>1</sup> For a review of this subject see "Hydrogen Fluoride and Its Solutions," Simons, *Chem. Reviews*, **8**, 213 (1931).

<sup>2</sup> Simons and Hildebrand, *THIS JOURNAL*, **46**, 2183 (1924).

<sup>3</sup> Simons, *ibid.*, **46**, 2179 (1924). In this paper an error is made in calculating  $\Delta H$ , which should be 6025 calories per mole.

<sup>4</sup> Kolosovskii, *Bull. soc. chim.*, **41**, 422 (1927).